



Instructions for the following series products:

SB Series Heavy-Duty SRLs

(See back pages for specific model numbers.)

User Instruction Manual Self Retracting Lifeline 3000057 Series and 3000150 Series

This manual is intended to meet the Manufacturer's Instructions as required by ANSI Z359.1 and the Canadian Standards Association, and should be used as part of an employee training program as required by OSHA.

WARNING: *This product is part of a personal fall arrest system. The user must read and follow the manufacturer's instructions for each component of the system. These instructions must be provided to the user of this equipment. The user must read and understand these instructions before using this equipment. Manufacturer's instructions must be followed for proper use and maintenance of this equipment. Alterations or misuse of this equipment, or failure to follow instructions, may result in serious injury or death.*

IMPORTANT: *If you have questions on the use, care, application, or suitability of this safety equipment, contact DBI/SALA.*

IMPORTANT: *Before using this equipment, record the product identification information from the ID label in the inspection and maintenance log in section 9.0 of this manual.*



Figure 1 - 300057 Series and 3000150 Series

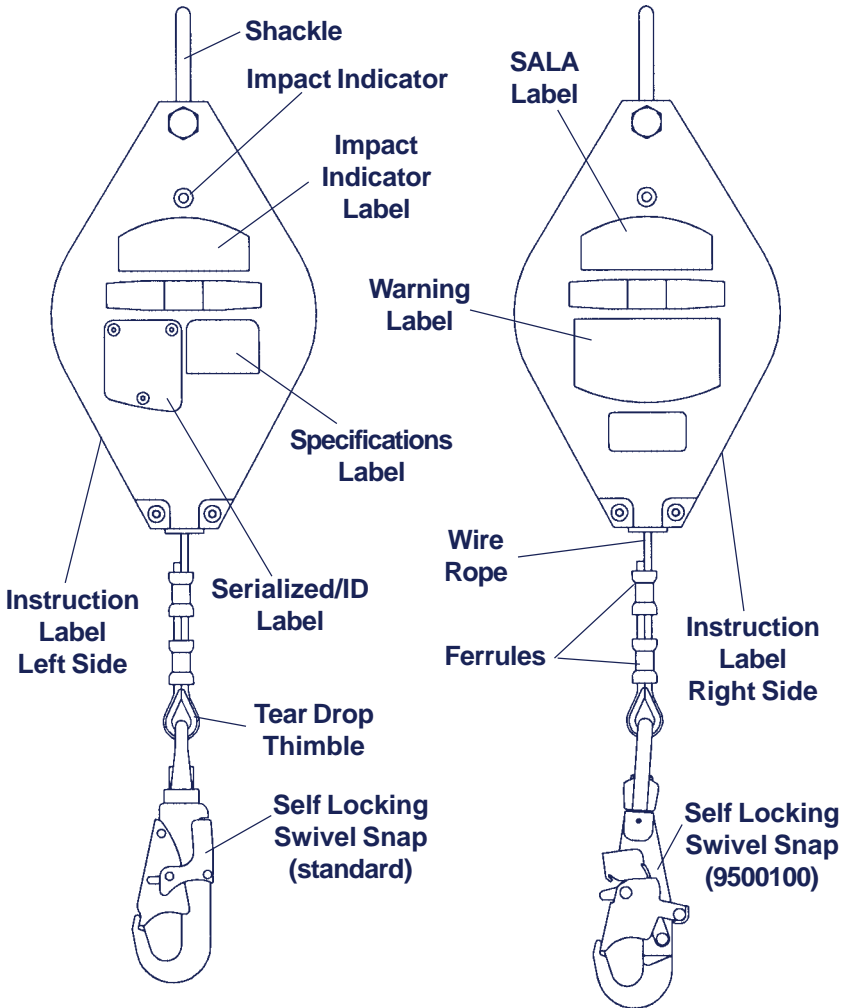

Hook Options

Stainless Steel Self Locking Swivel Snap (2100000)



Aluminum Auto Locking Carabiner (R-0009)

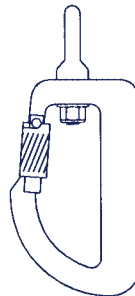

DESCRIPTIONS

3000057 (SB57) Self Retracting Lifeline: 20 foot of 3/16 in. galvanized wire rope, alloy steel self locking swivel snap

3000058 (SB57RL) Self Retracting Lifeline: 20 foot of 3/16 in. stainless steel wire rope, alloy steel self locking swivel snap

3000150 (SB150) Self Retracting Lifeline: 39 foot of 3/16 in. galvanized wire rope, alloy steel self locking swivel snap

3000151 (SB150RL) Self Retracting Lifeline: 39 foot of 3/16 in. stainless steel wire rope, alloy steel self locking swivel snap

1.0 APPLICATIONS

1.1 PURPOSE: DBI/SALA self retracting lifelines (SRL) are components in personal fall arrest systems (PFAS). They are to be used in situations where worker mobility and fall protection is needed (inspection work, general construction, maintenance work, oil production, confined space work, etc.)

A. FALL ARREST: The SRL is used as part of a complete fall arrest system. Such systems typically include a full body harness, anchorage connector (i.e. carabiner) and the SRL. This type of system is used where a fall hazard exists.

1.2 LIMITATIONS: The following application limitations must be considered before using this product:

A. CORROSION: Do not leave this equipment for long periods in environments where corrosion of metal parts could take place as a result of vapors from organic materials. Use caution when working around sewage or fertilizer because of their high concentration of ammonia, which is very corrosive. Use near seawater or other corrosive environments may require more frequent inspections or servicing to ensure corrosion damage is not affecting the performance of the product.

B. CHEMICAL HAZARDS: Solutions containing acid or caustic chemicals, particularly at elevated temperatures, may damage DBI/SALA SRL's. When working with such chemicals, frequent inspection of the entire SRL must be completed. Chemical damage to the lifeline is difficult to detect and it is recommended that the lifeline be replaced periodically to ensure safety. The lifeline must be replaced by an authorized service agent. Consult DBI/SALA if in doubt about using this equipment around chemical hazards.

- C. **HEAT:** This equipment is not designed for use in high temperature environments. Provide protection for this equipment when using near welding, metal cutting, or similar activities. Hot sparks may burn or damage this equipment. Contact DBI/SALA for details on use of this equipment in high temperature environments.
- D. **ELECTRICAL HAZARDS:** Use caution when the lifeline may contact high voltage power lines. There is a possibility of electric current flowing through the lifeline. Use caution where the lifeline may contact high voltage power lines.
- E. **CAPACITY:** The SRL is for use by persons with a combined weight (person, clothing, tools, etc.) of 75 lbs. minimum and 300 lbs. maximum. No more than one person can connect to an SRL for fall arrest applications.
- F. **LOCKING SPEED:** Situations which do not allow for an unobstructed fall path should be avoided. Working in confined or cramped spaces may not allow sufficient speed to cause the SRL to lock in a fall. Working on slowly shifting materials, such as sand or grain, may not allow sufficient speed to cause the SRL to lock. A similar situation may occur on low pitched roofs, where a worker may slide instead of fall. A clear path is required to ensure positive locking of the SRL.
- G. **NORMAL OPERATION:** Normal operation will allow the full length of the lifeline to extend and retract as the worker moves. The lifeline must remain taut at all times during normal use. If the lifeline is slack, the SRL must be taken out of service and inspected. If a fall occurs, a speed sensing brake system will activate, stopping the fall and absorbing much of the energy created. For falls that occur near the end of the lifeline travel, the reserve lifeline system will ensure a reduced impact fall arrest. If a fall has been arrested, the SRL must be taken out of service and inspected. See section 5.0. Sudden or quick movements should be avoided during the normal work operation, as this may cause the SRL to lock-up.
- H. **TRAINING:** This equipment must be installed and used by persons trained in its correct application and use.

1.3 Refer to national standards, including ANSI Z359.1 and applicable local, state, and federal (OSHA) requirements governing this equipment for more information on personal fall arrest systems and associated system components.

2.0 SYSTEM REQUIREMENTS

- 2.1 COMPATIBILITY OF COMPONENTS:** DBI/SALA equipment is designed for use with DBI/SALA approved components and subsystems only. Substitutions or replacements made with non-approved components or subsystems may jeopardize compatibility of equipment and may effect the safety and reliability of the complete system.
- 2.2 COMPATIBILITY OF CONNECTORS:** Connectors are considered to be compatible with connecting elements when they have been designed to work together in such a way that their sizes and shapes do not cause their gate mechanisms to inadvertently open regardless of how they become oriented. Contact DBI/SALA if you have any questions about compatibility.

Connectors (hooks, carabiners, and D-rings) must be capable of supporting at least 5,000 lbs. (22.2 kN). Connectors must be compatible with the anchorage or other system components. Do not use equipment that is not compatible. Non-compatible connectors may unintentionally disengage. See Figure 2. Connectors must be compatible in size, shape, and strength. Self locking snap hooks and carabiners are required by ANSI Z359.1 and OSHA.

Figure 2 - Unintentional Disengagement (Roll-out)

If the connecting element that a snap hook (shown) or carabiner attaches to is undersized or irregular in shape, a situation could occur where the connecting element applies a force to the gate of the snap hook or carabiner. This force may cause the gate (of either a self-locking or a non-locking snap hook) to open, allowing the snap hook or carabiner to disengage from the connecting point.

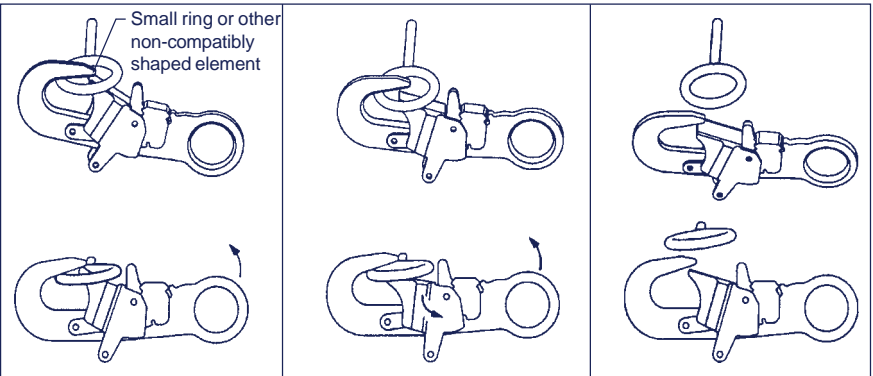

1. Force is applied to the snap hook.

2. The gate presses against the connecting ring.

3. The gate opens allowing the snap hook to slip off.

2.3 Making Connections: Only use self-locking snap hooks and carabiners with this equipment. Only use connectors that are suitable to each application. Ensure all connections are compatible in size, shape and strength. Do not use equipment that is not compatible. Ensure all connectors are fully closed and locked.

DBI/SALA connectors (snap hooks and carabiners) are designed to be used only as specified in each product's user's instructions. See Figure 3 for inappropriate connections. DBI/SALA snap hooks and carabiners should not be connected:

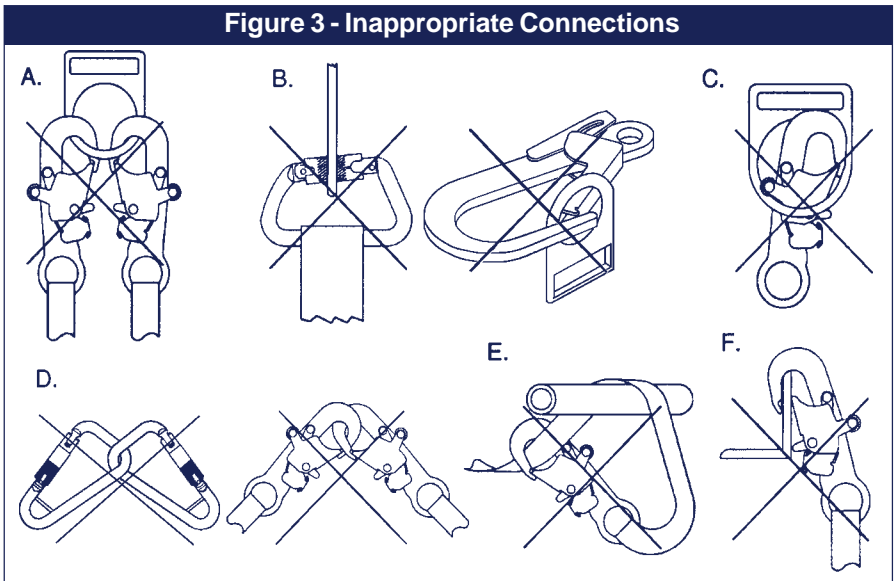

- A. To a D-ring to which another connector is attached.
- B. In a manner that would result in a load on the gate.

NOTE: Large throat opening snap hooks should not be connected to standard size D-rings or similar objects which will result in a load on the gate if the hook or D-ring twists or rotates. Large throat snap hooks are designed for use on fixed structural elements such as rebar or cross members that are not shaped in a way that can capture the gate of the hook.

- C. In a false engagement, where features that protrude from the snap hook or carabiner catch on the anchor and without visual confirmation seems to be fully engaged to the anchor point.
- D. To each other.

- E. Directly to webbing or rope lanyard or tie-back (unless the manufacturer's instructions for both the lanyard and connector specifically allow such a connection).
- F. To any object which is shaped or dimensioned such that the snap hook or carabiner will not close and lock, or that roll-out could occur.

2.4 ANCHORAGE STRENGTH: Anchorages selected for personal fall arrest systems shall be capable of sustaining static loads applied in the directions permitted by the PFAS of at least; (A) 3,600 lbs. (16kN) when certification exists (see ANSI Z359.1 for certification definition), or (B) 5,000 lbs. (22.2kN) without certification. When more than one PFAS is attached to an anchorage, the anchorage strengths set forth in (A) and (B) must be multiplied by the number of personal fall arrest systems attached to the anchorage.

From OSHA 1926.500 and 1910.66: Anchorages used for attachment of a personal fall arrest system shall be independent of any anchorage being used to support or suspend platforms, and must support at least 5,000 lbs. per user attached; or be designed, installed, and used as part of a complete personal fall arrest system which maintains a safety factor of at least two, and is supervised by a qualified person.

- 2.5 In applications where an SRL is used in conjunction with a horizontal system (i.e. horizontal I-beams, trolleys), the SRL and horizontal system components must be compatible. Horizontal systems must be designed and installed under the supervision of a qualified engineer.
- 2.6 When using an SRL with a support structure (i.e. tripod, davit arm), ensure the support structure is compatible with the connection, operation, stability, and strength of the SRL.

3.0 OPERATION AND USE

WARNING: Do not alter or intentionally misuse this equipment. Consult DBI/SALA when using this equipment in combination with components or subsystems other than those described in this manual. Some subsystem and component combinations may interfere with the operation of this equipment. Use caution when using this equipment around moving machinery, electrical and chemical hazards, and sharp edges.

WARNING: Consult your doctor if there is reason to doubt your fitness to safely absorb the shock from a fall arrest. Age and fitness seriously affect a worker's ability to withstand falls. Pregnant women or minors must not use DBI/SALA self retracting lifelines.

- 3.1 BEFORE EACH USE** of this equipment, carefully inspect it according to steps listed in section 5.0.
- 3.2 PLANNING:** Plan your fall protection system and how it will be used before starting your work. Consider all factors that will affect your safety before, during, and after a fall. The following list gives some important points to consider when planning your system:

A. ANCHORAGE: Select a rigid anchorage point that is capable of supporting 5,000 lbs. (22.2kN). See Figure 4 and section 2.4. The anchorage location must be carefully selected to reduce free fall and swing fall hazards, and to avoid striking an object during a fall. Do not work above your anchorage level to avoid an increased free fall distance.

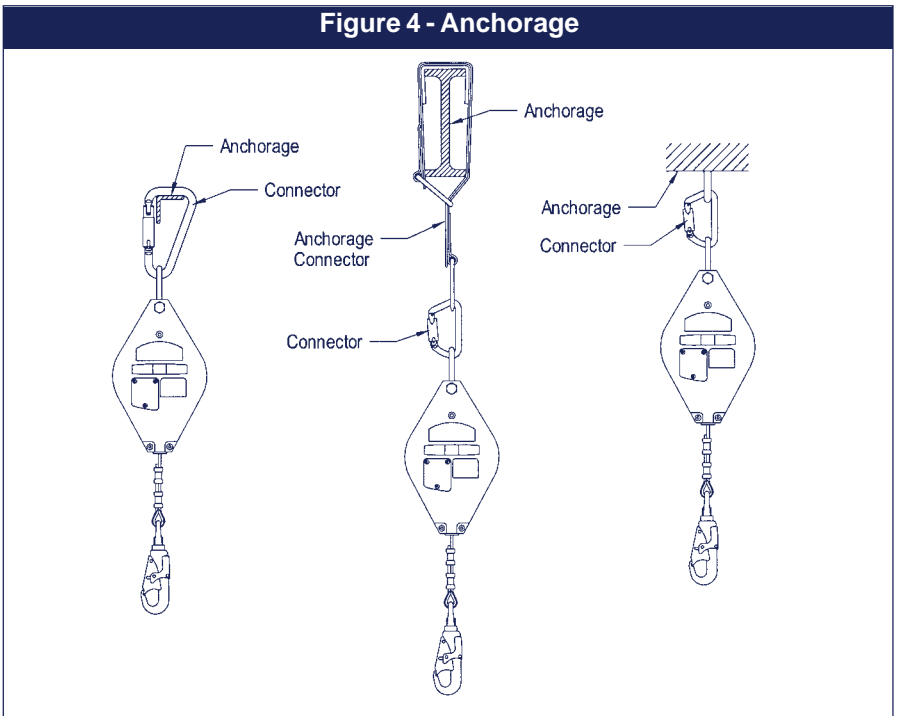

B. FREE FALL: Personal fall arrest systems must be rigged so the potential free fall is never greater than 6 feet. Avoid working above the anchorage level to avoid an increased free fall distance. Avoid working where your line may cross or tangle with that of another worker or object. Do not allow the lifeline to pass under arms or between legs. Never clamp, knot, or prevent the lifeline from retracting or being taut. Avoid slack line. Do not lengthen the SRL by connecting a lanyard or other components without consulting DBI/SALA.

C. SWING FALLS: Swing falls occur when the anchorage point is not directly above the point where a fall occurs. The force of striking an object in a swing fall may cause serious injury. In a swing fall, the total vertical fall distance will be greater than if the user had fallen directly below the anchorage point, thus increasing the total free fall distance and the area required to safely arrest the user. The SRL will activate regardless of its orientation relative to the user. The recommended work zone represents the typical acceptable work area for most applications. Review your specific application to determine what the appropriate work zone should be. See Chart 1. Minimize swing falls by working as directly below the anchorage point as possible. Never permit a swing fall if injury could occur. If a swing fall situation exists in your application contact DBI/SALA before proceeding. See Figure 5.

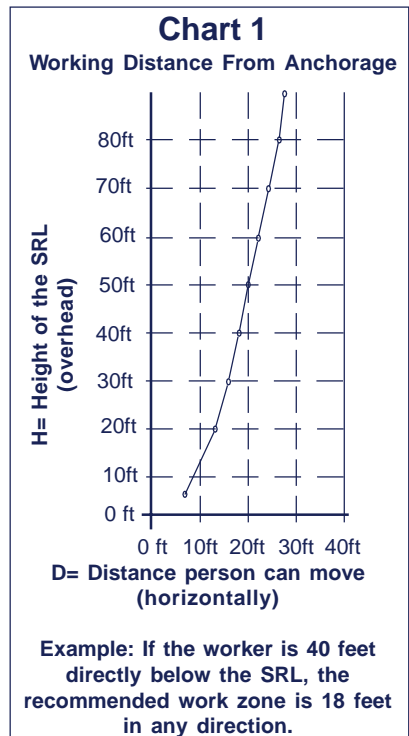

D. FALL CLEARANCE: Ensure adequate clearance exists in your fall path to prevent striking an object. A minimum of six feet from the working level to the lower level or nearest obstruction is recommended. See Figure 5.

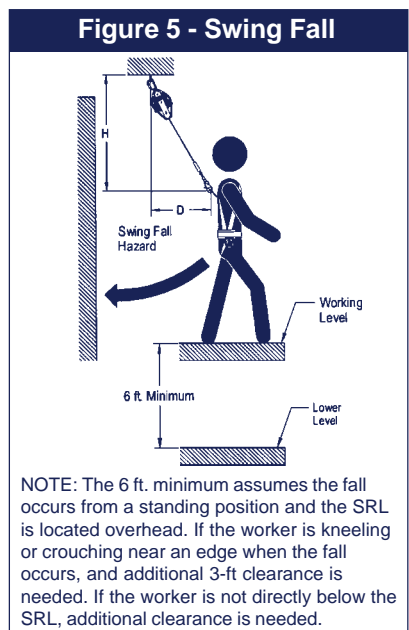

E. SHARP EDGES: Avoid working where the lifeline will be in contact with, or abrade against sharp edges. Provide protection for the lifeline when possible.

- F. **RESCUE:** If a fall occurs, the employer must have a rescue plan and the ability to implement a rescue.
- G. **AFTER A FALL:** Equipment which has been subjected to fall arrest forces must be removed from service for inspection. See section 5.0.

WARNING: Read and follow manufacturer's instructions for associated equipment (i.e. full body harness) used in your personal fall arrest system.

IMPORTANT: For custom versions of this product, see supplemental instructions, if included, for additional instructions.

- 3.3 **BODY SUPPORT:** When using DBI/SALA SRL's, a full body harness must be worn. For general fall protection use, connect to the back D-ring. For situations such as ladder climbing, attach to the front of the harness. This is acceptable provided the potential free fall is very short, and footing can be easily regained.

IMPORTANT: Do not use a body belt for free fall applications. See OSHA 1926.502 for guidelines.

- 3.4 **MAKING CONNECTIONS:** When using a hook to make a connection, ensure roll-out cannot occur. Roll-out occurs when interference between a hook and the mating connector causes the hook gate to unintentionally open and release. Self locking snap hooks or self locking/self closing gate carabiners must be used to reduce the possibility of roll-out when making connections. Do not use hooks or connectors that will not completely close over the attachment object. Do not use non-locking snap hooks. Follow the manufacturer's instructions supplied with each system component.

- 3.5 **OPERATION:** Inspect the SRL as described in section 5.0. Connect the SRL to a suitable anchorage or anchorage connector as described above. Connect the self locking snap hook or self locking/self closing carabiner on the end of the lifeline to the fall arrest or ladder climbing attachment on the full body harness. Ensure connections are compatible in size, shape, and strength. Ensure hook is securely closed and locked. See Figure 6.

- 3.6 **USE:** When attached to the SRL, the worker is free to move about within

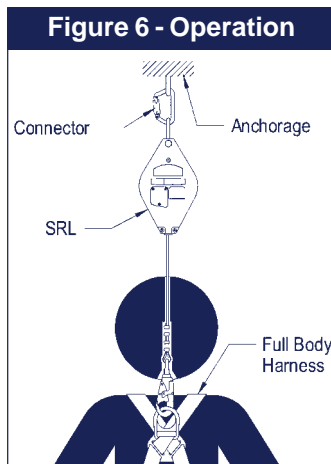

recommended working areas at normal speeds. Should a fall occur, the SRL will lock and arrest the fall. Upon rescue, remove the SRL from use. Inspect as described in section 5.0. When working with the SRL, allow the lifeline to recoil back into the device under control. A short tag line may be required to extend or retract the lifeline during connection and disconnection. Allowing the lifeline to be fully extended for long periods of time may cause premature weakening of the retraction spring.

4.0 TRAINING

- 4.1 It is the responsibility of the user and the purchaser of this equipment to assure that they are familiar with these instructions, trained in the correct care and use of, and are aware of the operating characteristics, application limits, and the consequences of improper use of this equipment.

IMPORTANT: *Training must be conducted without exposing the trainee to a fall hazard. Training should be repeated on a periodic basis.*

5.0 INSPECTION

5.1 FREQUENCY:

- **Before Each Use:** OSHA 1910.66, OSHA 1926.502 and ANSI Z359.1 requires an inspection of equipment before each use. See sections 5.2, 5.3, and 5.4 for inspection guidelines.
- **Annually:** ANSI Z359.1 requires a formal inspection of the SRL be completed by a competent person other than the user. More frequent inspections by a competent person may be required based on the nature and severity of workplace conditions affecting the equipment and the modes of use and exposure time of the equipment. See sections 5.2, 5.3, and 5.4 for inspection guidelines. Record results in the inspection and maintenance log in section 9.0.
*NOTE: In Canada, CSA requires SRLs to be serviced within two years of the manufactured date, and annually thereafter.
- **After a Fall Arrest:** Inspect impact indicator according to section 5.2, and the entire SRL according to sections 5.3 and 5.4.

WARNING: *If the self retracting lifeline has been subjected to fall arrest or impact forces, it must be removed from service and inspected according to sections 5.2 and 5.3.*

IMPORTANT: *Extreme working conditions (harsh environment, prolonged use, etc.) may require increasing the frequency of inspections.*

5.2 IMPACT INDICATOR: To inspect the impact indicator, look for an exposed red color button as shown in Figure 7. If the red button extends out past the housing surface, an impact loading has occurred. SRL's which have been subjected to impact loading must be removed from service for inspection. Return to an authorized service center for resetting.

5.3 INSPECTION STEPS:

- Step 1.** Inspect for loose screws and bent or damaged parts.
- Step 2.** Inspect housing for distortion, cracks or other damage. Ensure the shackle moves freely and is free from distortion, cracks, burrs and worn parts. Ensure that the nut is fully tightened.
- Step 3.** The lifeline must fully extend and fully retract. The lifeline must be taut (under tension).
- Step 4.** Ensure the device locks up when lifeline is jerked sharply. Lock-up must be positive, with no slipping.
- Step 5.** The labels must be present and fully legible. See section 8.0
- Step 6.** Look for signs of corrosion on the entire unit.
- Step 7.** Inspect lifeline. Look for cuts, kinks, burns, broken wires or strands, chemical damage, and severe abrasion. The lifeline must not be damaged.
- Step 8.** Inspect connecting hooks or carabiners for signs of damage, corrosion, and working condition.
- Step 9.** Inspect reserve lifeline payout (if present). If the SRL has the reserve lifeline feature, it may deploy if a fall has been arrested with most of the lifeline out. On newer models the retraction of the line will be hindered if the reserve lifeline has been deployed. Remove SRL from service if reserve lifeline has deployed (if present). See Figure 8.

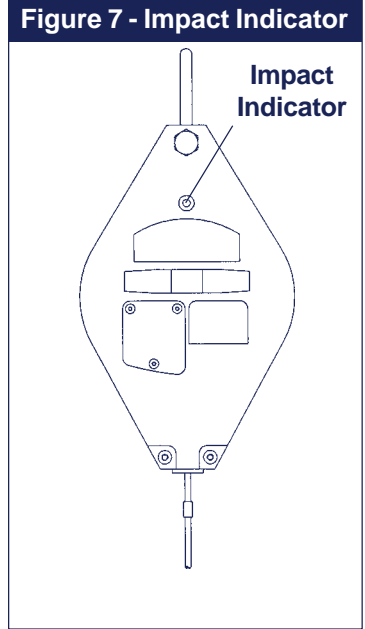

Step 10. Check the red Indicator Button to be sure that it is flush with the housing. If the button is not flush with the housing, the block has been deployed and must be removed from service. See Figure 8.

Step 11. Inspect each system component or subsystem per associated manufacturer's instructions.

Step 12. Record inspection results in inspection and maintenance log in section 9.0.

5.4 If inspection or operation reveals a defective condition, remove SRL from service and contact an authorized service center for repair.

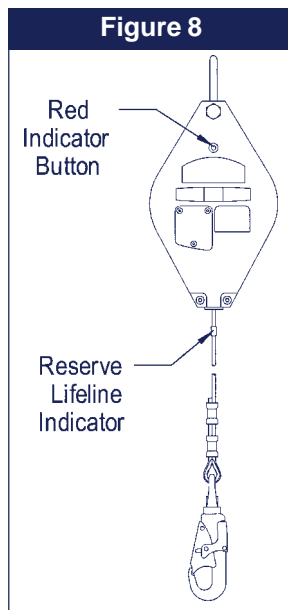

NOTE: Only DBI/SALA, or parties authorized in writing, may make repairs to this equipment.

6.0 MAINTENANCE, SERVICING, STORAGE

- 6.1** Periodically clean the exterior of the SRL with water and mild soap solution. Position the SRL so excess water can drain out. Clean labels as required.
- 6.2** Clean lifeline with water and mild soap solution. Rinse and thoroughly air dry. Do not force dry with heat. An excessive buildup of dirt, paint, etc., may prevent the lifeline from fully retracting, causing a potential free fall hazard. Replace the lifeline if there is excessive buildup.

WARNING: If the lifeline contacts acids, remove unit from service and wash with water and mild soap solution. Inspect unit before returning to service.

- 6.3** Lifeline replacement and additional maintenance and servicing procedures must be completed by an authorized service center. Authorization and a return number must be issued by DBI/SALA. Do not lubricate any parts. Do not disassemble the SRL. See section 5.1 for servicing frequency.
- 6.4** Clean and store body support and associated system components according to manufacturer's instructions.

- 6.5** Store SRL in a cool, dry, clean environment, out of direct sunlight. Avoid areas where chemical vapors may exist. Inspect the SRL after extended storage.

7.0 SPECIFICATIONS

7.1 DIMENSIONS:

Model	Working Range	Lifeline Type	Size (LxWxH)	Weight
3000057	20 feet	Galvanized Wire Rop	11x6 3/4x3"	13.25 lbs.
3000058	20 feet	Stainless Steel Wire Rope	11x6 3/4x3"	13.25 lbs.
3000150	39 feet	Galvanized Wire Rope	11 5/8x8x4 3/8"	22 lbs.
3000151	39 feet	Stainless Steel Wire Rope	11 5/8x8x4 3/8"	22 lbs.

Hook Model	Material	Description
Standard	Alloy Steel	Self-locking Snap Hook
2100000	Stainless Steel	Self-locking Swivel Snap Hook
9500100	Alloy Steel	Self-locking Swivel Snap Hook
R-009	Aluminum	Auto-lock Carabiner w/eye

See Figure 9

- * Includes approximately 2 feet emergency reserve.
- Maximum Arresting Force, all models: 900 lbs. when tested in accordance with ANSI Z359.1.
- Maximum Arresting Distance, all models: 42 inches.
- Capacity, all models: 75-300 lbs.
- Average Locking Speed, all models: 4.9 feet/second
- Meets ANSI Z359.1, and OSHA requirements, and CSA Z259.2 requirements.

Figure 9 - Working Range

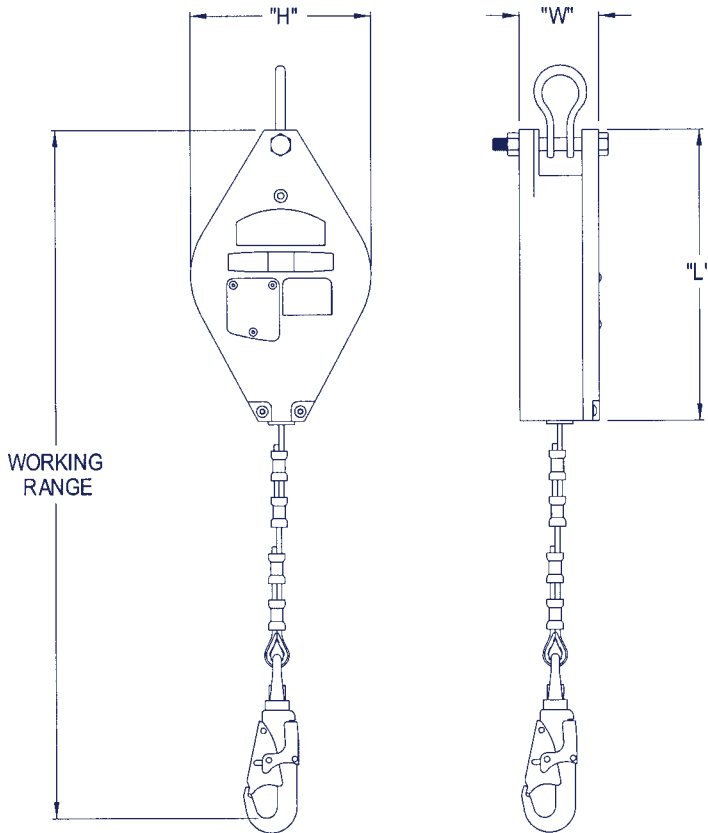

7.2 MATERIALS:

3000057, 3000058, 3000150, and 3000151

Housing: Aluminum

Drum: Aluminum

Fasteners: Stainless steel

Main Shaft: Stainless steel

Locking Pawls: Stainless steel

Motor Spring: Stainless steel

Finish: Anodized components

Lifeline (3000057, 3000150): 3/16 inch diameter galvanized wire rope, 4,200 lb. minimum tensile strength

Lifeline (3000058, 3000151): 3/16 inch diameter stainless steel wire rope, 3,600 lb. minimum tensile strength

8.0 LABELING

8.1 The following labels must be present and fully legible:



SALA Label



Impact Indicator Label



Specification Label

Warning Label

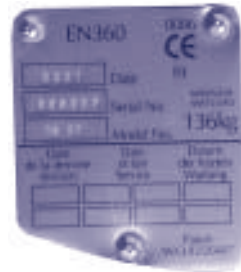

ID Label

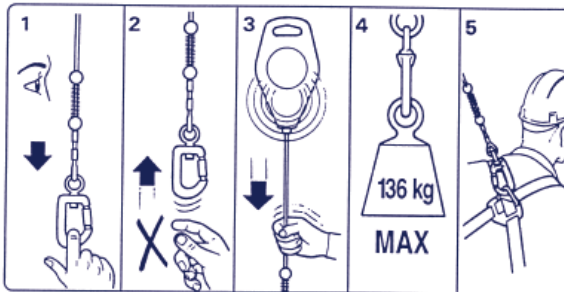

Instruction Label left side

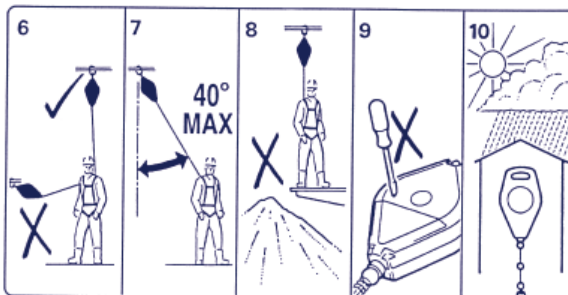

Instruction Label right side

9.0 INSPECTION AND MAINTENANCE LOG

SERIAL NUMBER: _____

MODEL NUMBER: _____

DATE PURCHASED: _____

INSPECTION DATE	INSPECTION ITEMS NOTED	CORRECTIVE ACTION	MAINTENANCE PERFORMED
Approved By: _____			
Approved By: _____			
Approved By: _____			
Approved By: _____			
Approved By: _____			
Approved By: _____			
Approved By: _____			
Approved By: _____			
Approved By: _____			
Approved By: _____			
Approved By: _____			
Approved By: _____			

WARRANTY

Equipment offered by DBI/SALA is warranted against factory defects in workmanship and materials for a period of two years from date of installation or use by the owner, provided that this period shall not exceed two years from date of shipment. Upon notice in writing, DBI/SALA will promptly repair or replace all defective items. DBI/SALA reserves the right to elect to have any defective item returned to its plant for inspection before making a repair or replacement. This warranty does not cover equipment damages resulting from abuse, damage in transit, or other damage beyond the control of DBI/SALA. This warranty applies only to the original purchaser and is the only one applicable to our products, and is in lieu of all other warranties, expressed or implied.

This instruction applies to the following models:

3000057	3000151
3000058	3000152
3000059	3000153
3000150	

Additional model numbers may appear on the next printing of these instructions.



USA

3965 Pepin Avenue
Red Wing, MN 55066-1837
Toll Free: 800-328-6146
Phone: (651) 388-8282
Fax: (651) 388-5065
email: info@dbisala.com

Canada

260 Export Boulevard
Mississauga, Ontario L5S 1Y9
Toll Free: 800-387-7484
Phone: (905) 795-9333
Fax: (905) 795-8777
email: info@dbisala.com

United Kingdom

Unit 7 Christleton Court
Manor Park
Runcorn, Cheshire WA71ST
Tel. 01928 57 13 24
Fax 01928 57 13 25
email: info@salagroupco.uk

Germany

Flustr. 63, D-47533
Kleve, Germany
Tel: +(49) 2821 7533 0
Fax: +(49) 2821 7533 20
email: info@csgne.de

Sweden

P.O. Box 134, Fridhemsgatan 4
S-733 22 Sala, Sweden
Tel: +(46) 224 37585
Fax: +(46) 224 15253
email: info@csgne.se

This manual is available for download at www.salagroup.com



Certificate No. FM 39709

Form: 5902117
Rev: B